

**** **GLIDER WINCH GUILLOTINE** ****
DESIGNED AND MANUFACTURED
BY

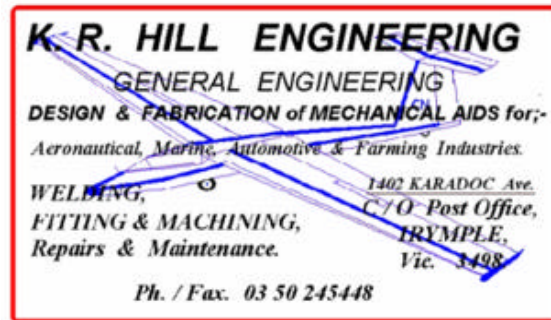

Email. trickie@inet.net.au

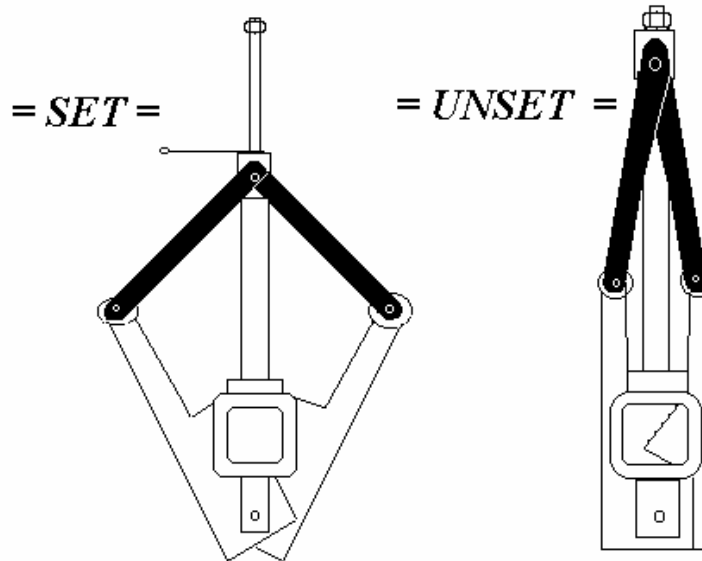

July 16, 2003

GUARD AND ROLLER ASSEMBLY NOT SHOWN

Tested on 2.8mm ht. 3.2mm ht. & multi-strand wire / cable.& Poly Rope (with excellent results)

Height approx 390 mm

Set width approx 250 mm

Side width (View not shown) 120 mm. (without guide rollers) approx 8Kg

250 mm. (with rollers & guide assemb.) approx 15Kg

Cost to make unit , Basic Guillotine only \$250. plus freight (plus GST)

Guillotine with 42mm bearings & 48mm Dia. Guide Rollers. \$450. plus freight. (plus GST)

Instructions & templates on how to build. With spring supplied \$30. per unit. Plus postage (plus GST)

Optional extras;- trigger "T" handle and director tube with 2M multi strand cable. \$20 (plus GST)

Drift kit for bearing removal / replacement of guide rollers. \$35. (plus GST)

Under normal circumstances delivery would be about 4 weeks. (Manufactured as required)

Modifications and attachments as required.

If you can supply photos of the Winch set-up I may be able to help with adoptions.

Design and construction of mounting devices /attachments will incur additional costs.

For references;-

Sunraysia Gliding Club, winch fitted with two (prototypes.)

Gympie Soaring Club, supplied with three Guillotines only.

Caboolture Gliding Club, supplied with Guillotine and Roller assembly.

Lake Keepit Soaring Club, supplied with Guillotine with larger Roller assembly plus Mounting arms and trigger kit.

Cental Coast Soaring Club, supplied with Guillotine (Modified to suit larger Dia. Guide Tube).and trigger attachments.

Harden Gliding Club, supplied with 2 Guillotine and Guide rollers. (mounted horizontally) (heavy duty guarding)

Regards Keith Hill.

Happy soaring.

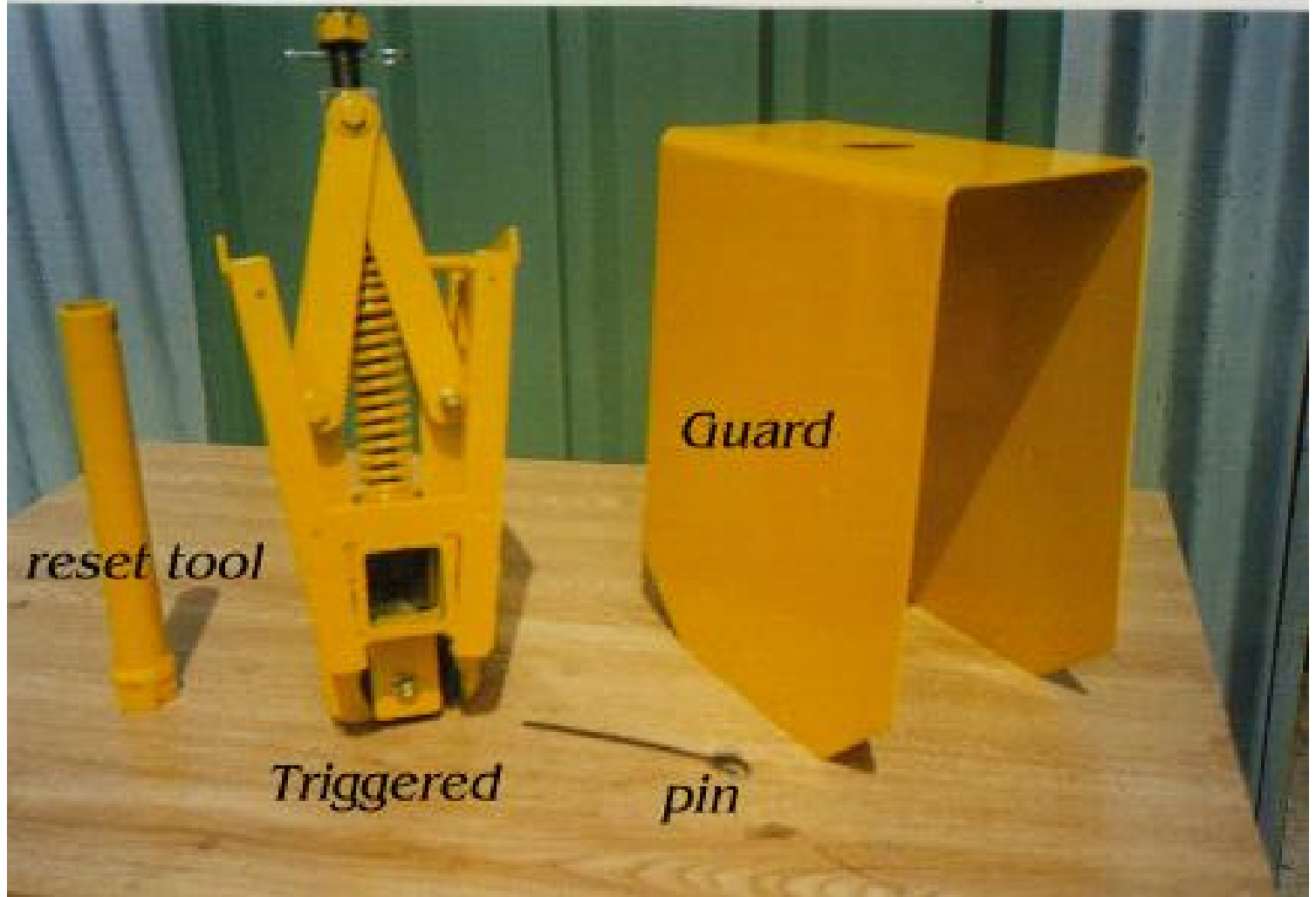
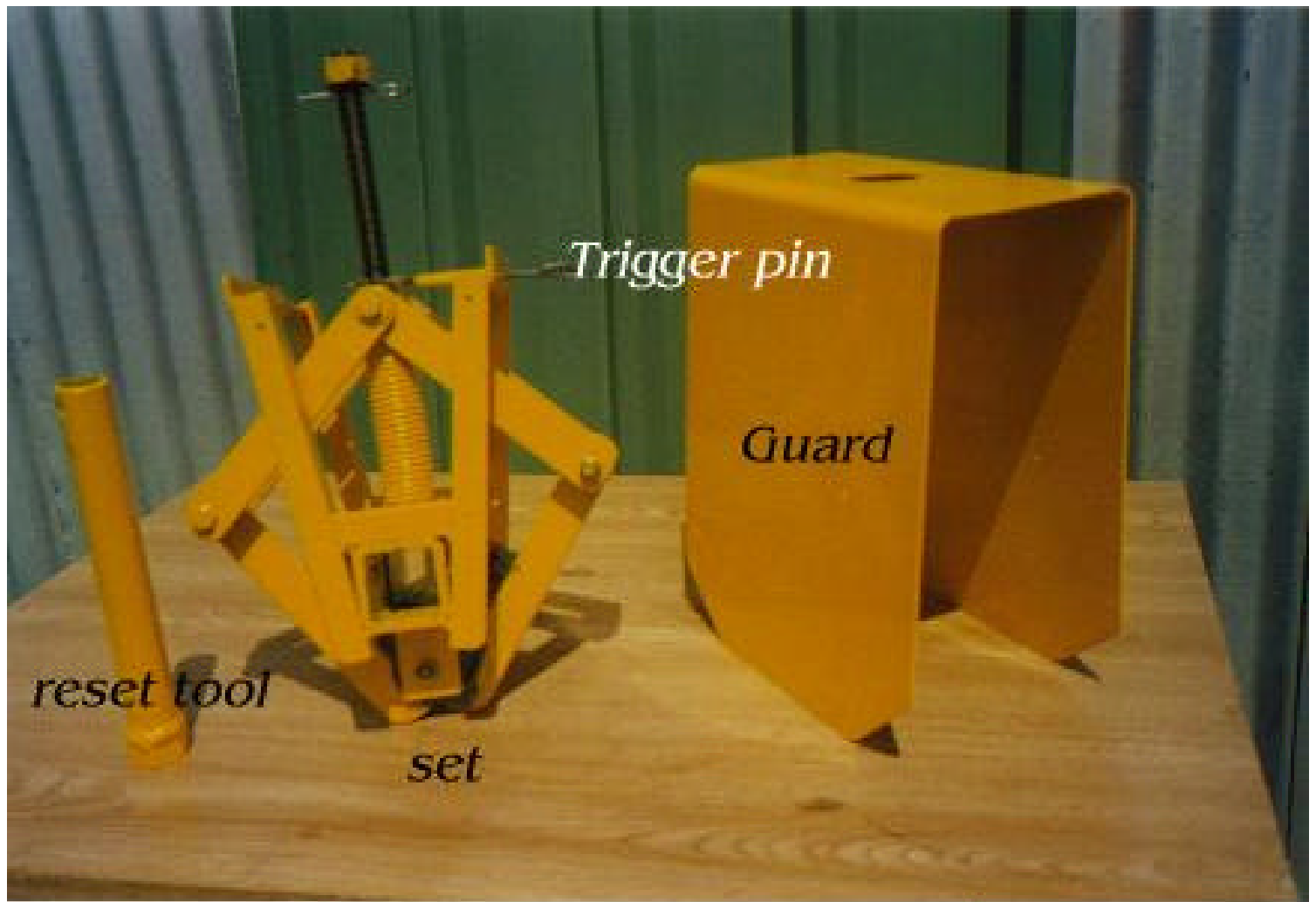

HARDEN GLIDING CLUB

